



Book 2013



www.gipiemme.com



Dal 1964

Gipiemme, prestigiosa e storica azienda del ciclo italiano, si distingue da sempre per la continua innovazione tecnologica ed il design italiano. Fondata nel 1964 **Gipiemme** si afferma da subito tra i principali produttori mondiali di gruppi completi per ciclo, innovando continuamente i propri prodotti. Nel 1980 **Gipiemme** inizia la produzione di congiunzioni per telai e crea la prima produzione di ruote complete da pista e da cronometro. Queste rivoluzionarie ruote in fibra di vetro, denominate "lenticolari" proprio per la tipica forma a "lente", sono l'inizio dello sviluppo di questo eccezionale tipo di prodotto. Nel 1984 nasce la prima ruota interamente in carbonio e nel 1989 **Gipiemme** dà il via all'esclusiva produzione di ruote a razze in alluminio ed in carbonio, dotate di tecnologia aeronautica. Nel corso del 1992 **Gipiemme** completa la sua gamma di prodotti rivoluzionando la ruota classica a raggi, lanciando così il modello Tecno 416. Nel 1999 **Gipiemme** presenta la prima ruota alleggerita a CNC, nonché le ruote con raggi raggruppati a coppie a terne e a quaterne.

In questo nuovo Catalogo 2013 **Gipiemme** presenta una linea ulteriormente modificata e rinnovata, sempre più all'avanguardia in quanto frutto dell'esperienza di molteplici anni di ricerca, di continuo sviluppo e di accurati test. Il risultato che ne scaturisce è una vasta e completa gamma di ruote performanti che sapranno dar vita alle vostre migliori prestazioni agonistiche.

I NOSTRI CERCHI, RUOTE E MANUBRI SONO INTERAMENTE PRODOTTI IN ITALIA, NELLO STABILIMENTO DI LORIA (TV).

Since 1964

Gipiemme, prestigious and historical trade mark of Italian cycling, it distinguishes itself from its competitors for its continuous innovation, technology and for its exclusive Italian design. Was founded in 1964 and it became the first world producer of the complete group set for cycling and continues to show innovation and improvement in its products. **Gipiemme** created the first production wheel for track and time trial in 1980. This revolutionary wheel in fiber glass, called "Lenticolare", due to the typical lent form was the first step in the development of this extraordinary product. The first carbon fiber wheel was created in 1984. In 1989 **Gipiemme** commenced the production of wheels with aluminium and carbon spokes adopting technology used in the aeronautical industry. 1992 saw **Gipiemme** complete the range of innovative classic rayed wheels by introducing to the market the model "TECNO 416". In 1999 **Gipiemme** produced the first lightweight wheel in CNC and wheels with grouped spokes in pairs, triple and quadruple configuration.

The new 2013 catalogue for **Gipiemme** presents a restyled and rejuvenated range developed after many years of research, technological development and testing. The result is a new and complete range of high performance wheels that will bring out the rider's best performance.

THE RIMS, WHEELS, AND HANDLEBARS MADE BY GIPIEMME AND NISI ARE ALL PRODUCED IN THE FACTORY LOCATED IN LORIA, (TV) ITALY.

<Linea Corsa Carbonio

<Carbon Racing Line



PG 6 MANTA CRONO PG 7 CARBON H6.0 LIGHT PG 8 CARBON H5.5 SPEED PG 9 EQUIPE H5.5 CARBON



PG 10 CICLO CROSS H4.0 CARBON PG 11 CARBON H4.0 TUBOLARE PG 12 CARBON H4.0 SPEED PG 13 CARBON H2.5 TUBOLARE PG 14 CARBON H2.5 SPEED

<Linea Corsa Alluminio

<Aluminium Racing Line



PG 15 TECNO 1.55 ULTRALIGHT PG 16 KRONO ULTRALIGHT



PG 17 EQUIPE 716 PG 18 TECNO 716 LIGHT PG 19 TECNO 1.55 EQUIPE PG 20 TECNO 020

<Linea Pista/ScattoFisso

<Track/Single Speed Line



PG 22 MANTA PISTA PG 23 PISTA H6.0



PG 24 PISTA K 28 PG 25 PISTA A40 PISTA A40 fixed PG 26 PISTA STREET PG 27 PISTA 030 PG 28 PISTA FIXED

<Linea MTB

<MTB Line



PG 29 SIERRA CX LIGHT PG 30 KENYA 29" 26" ULTRALIGHT



PG 31 KENYA 27,5" ULTRALIGHT PG 32 T584 MTB CARBON PG 33 ROCCIA PG 34 ROCCIA 27,5" 26" PG 35 T-REX ENDURO



<UTILIZATION

- Road ●●●●●
- Chrono ●●●●●●●
- Cyclocross ●●●
- track

Book
2013

<UTILIZATION

- Road ●●●●●
- Chrono ●●●●●●●
- Cyclocross ●●●
- track

<MANTA
crono tubolare

<PROFILE

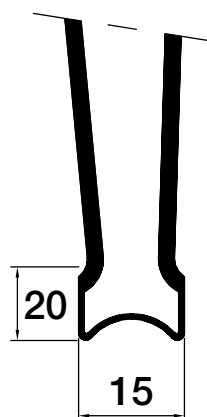
<H6.0 Carbon
tubolare

Disponibile in versione Carbon H4.6
(40 mm ant. - 60 mm post.)

Available as version Carbon H4.6
(40 mm front - 60 mm rear)

Autorizzato U.C.I. - Authorized from U.C.I.
Certificato a norme UNI.CE.EN 14781
Certified to norm UNI.CE.EN 14781

<PROFILE

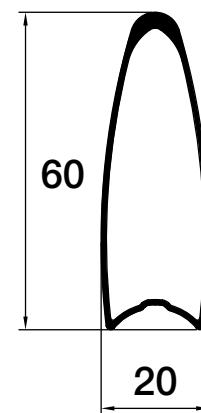

| | | | |
|-----------|--|----------|-------------------|
| MODELLO | Tubolare 28" 700 C | | |
| ETRTO | 632-20 din | O.L.D. | 100/130 |
| VERSIONI | Campagn.-Shimano-Sram | FINITURA | Fibra di carbonio |
| CERCHIO | 100% fibra di carbonio foro valvola 6.5 mm | | |
| RAGGI | N/P | | |
| NIPPLES | N/P | | |
| MOZZI | Alluminio Ergal su cuscinetti | | |
| BLOCCAGGI | Alluminio forgiato peso 55 gr. | | |
| PESO | Ant. 1078 gr. - Post. 1225 gr. (+/- 7%) | | |

| | | | |
|----------|---|--------|--------------|
| MODEL | Tubular 28" 700 C | | |
| ETRTO | 632-20 din | O.L.D. | 100/130 |
| VERSIONS | Campagn.-Shimano-Sram | FINISH | Carbon fiber |
| RIM | 100% carbon fiber valve hole 6.5 mm | | |
| SPOKES | N/P | | |
| NIPPLES | N/P | | |
| HUB | Aluminium Ergal with sealed bearings | | |
| Q.R. | Forged alloy weight 55 gr. | | |
| WEIGHT | Front 1078 gr. - Rear 1225 gr. (+/- 7%) | | |

| | | | |
|-----------|---|----------|-------------------|
| MODELLO | Tubolare 28" 700 C | | |
| ETRTO | 632-20 din | O.L.D. | 100/130 |
| VERSIONI | Campagn.-Shimano-Sram | FINITURA | Fibra di carbonio |
| CERCHIO | Monoscocca 100% fibra di carbonio alto 60 mm - foro valvola 6.5 mm | | |
| RAGGI | Sapim CXRay 20 inox aéro sfinati - post. inc. x 2 ant. radiali | | |
| NIPPLES | Autobloccanti ABS L 13 in Ergal con rondelle | | |
| MOZZI | Versione GPMCHlight, alluminio forgiato, cassetta Ergal su cuscinetti | | |
| BLOCCAGGI | Alluminio forgiato peso al paio 110 gr | | |
| PESO | Ant. 631 gr. - Post. 800 gr. - Tot. 1431 gr. (+/- 7% senza bloccaggi) | | |

| | | | |
|----------|--|--------|--------------|
| MODEL | Tubular 28" 700 C | | |
| ETRTO | 632-20 din | O.L.D. | 100/130 |
| VERSIONS | Campagn.-Shimano-Sram | FINISH | Carbon fiber |
| RIM | 100% carbon fiber monocoque height 60 mm - valve hole 6.5 mm | | |
| SPOKES | Sapim CXRay 20 stainless steel aéro-spoke, double size Front radial, Rear cross by 2 | | |
| NIPPLES | Self-locking ABS L 13 Ergal with washers | | |
| HUB | GPMCHlight, forged aluminium with Ergal cassette on sealed bearings | | |
| Q.R. | Forged aluminium - weight 110 gr. | | |
| WEIGHT | Front 631 gr. - Rear 800 gr. Tot. 1431 gr. (+/- 7% without quick release) | | |

<UTILIZATION

- Road** ●●●●●●
- Chrono** ●●●●●●
- Cyclocross**
- Track**

Book
2013

<UTILIZATION

- Road** ●●●●●●
- Chrono** ●●●●●●
- Cyclocross**
- Track**

<H5.5 Carbon
speed

Disponibile in versione Carbon H5.4 speed
(40 mm ant. - 55 mm post.) - Versione Professional

Available as version Carbon H5.4 speed
(40 mm front - 55 mm rear) - Professional Version

Autorizzato U.C.I. - Authorized from U.C.I.
Certificato a norme UNI.CE.EN 14781
Certified to norm UNI.CE.EN 14781
Certificato T.Ù.V. n°MEC02060
T.Ù.V. certified n°MEC02060

<PROFILE

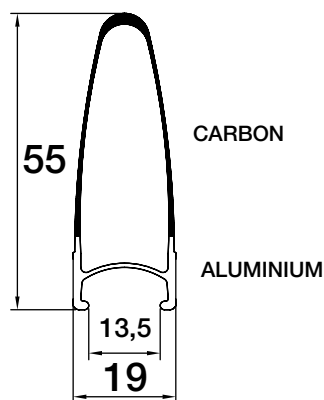

<H5.5 Equipe

Autorizzato U.C.I. - Authorized from U.C.I.
Certificato a norme UNI.CE.EN 14781 - Certified to norm UNI.CE.EN 14781
Certificato T.Ù.V. n°MEC02060 - T.Ù.V. certified n°MEC02060

<PROFILE

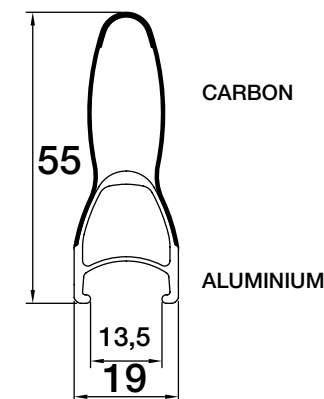

| | | | |
|-----------|--|----------|-------------------|
| MODELLO | Copertoncino 28" 700 C | | |
| ETRTO | 622-13,5 din | O.L.D. | 100/130 |
| VERSIONI | Campagn.-Shimano-Sram | FINITURA | Fibra di carbonio |
| CERCHIO | Carbonio strutturale e alu 6082-T6 saldato, forato a CNC foro valvola 6.5 mm | | |
| RAGGI | Sapim CXRay Inox aero sfinati - 20 post. inc. x 2 20 ant. radiali | | |
| NIPPLES | Autobloccanti ABS L 13 in Ergal con rondelle | | |
| MOZZI | Versione GPMChlight, alluminio forgiato, cassetta Ergal su cuscinetti | | |
| BLOCCAGGI | Alluminio forgiato peso al paio 110 gr | | |
| PESO | Ant. 757 gr. - Post. 928 gr. - Tot. 1685 gr. (+/- 7% senza bloccaggi) | | |

| | | | |
|----------|---|--------|--------------|
| MODEL | Clincher 28" 700 C | | |
| ETRTO | 622-13,5 din | O.L.D. | 100/130 |
| VERSIONS | Campagn.-Shimano-Sram | FINISH | Carbon fiber |
| RIM | structural carbon fiber with alu 6082-T6 welded, CNC holes, valve hole 6.5 mm | | |
| SPOKES | Sapim CXRay 20 stainless steel aero spokes double size, Front and rear left radial, Rear cross by 2 | | |
| NIPPLES | Self-locking ABS L 13 Ergal with washers | | |
| HUB | GPMChlight forged aluminium with Ergal cassette on sealed bearings | | |
| Q.R. | Forged aluminium - weight 110 gr. | | |
| WEIGHT | Front 757 gr. - Rear 928 gr. Tot. 1685 gr. (+/- 7% without quick release) | | |

| | | | |
|-----------|--|----------|-------------------|
| MODELLO | Copertoncino 28" 700 C | | |
| ETRTO | 622-13,5 din | O.L.D. | 100/130 |
| VERSIONI | Campagn.-Shimano-Sram | FINITURA | Fibra di carbonio |
| CERCHIO | Carbonio strutturale e alu 6082-T6 saldato, forato a CNC foro valvola 6.5 mm | | |
| RAGGI | SAPIN 16/20 raggi acciaio inox | | |
| NIPPLES | Autobloccanti ABS L 13 in Ergal con rondelle | | |
| MOZZI | Versione GPMJ, alluminio forgiato, cassetta Ergal su cuscinetti | | |
| BLOCCAGGI | Alluminio forgiato peso al paio 110 gr | | |
| PESO | Ant. 895 gr. - Post. 1095 gr. - Tot. 1990 gr. (+/- 7% senza bloccaggi) | | |

| | | | |
|----------|---|--------|--------------|
| MODEL | Clincher 28" 700 C | | |
| ETRTO | 622-13,5 din | O.L.D. | 100/130 |
| VERSIONS | Campagn.-Shimano-Sram | FINISH | Carbon fiber |
| RIM | structural carbon fiber with alu 6082-T6 welded, CNC holes, valve hole 6.5 mm | | |
| SPOKES | SAPIN 16/20 stainless spokes | | |
| NIPPLES | Self-locking ABS L 13 Ergal with washers | | |
| HUB | GPMJ forged aluminium with Ergal cassette on sealed bearings | | |
| Q.R. | Forged aluminium - weight 110 gr. | | |
| WEIGHT | Front 895 gr. - Rear 1095 gr. Tot. 1990 gr. (+/- 7% without quick release) | | |



<UTILIZATION

- R**oad ●●
- C**hrono ●●
- C**yclocross ●●●●●●
- T**rack

Book
2013

<UTILIZATION

- R**oad ●●●●●●
- C**hrono ●●●●
- C**yclocross ●●●●●●
- T**rack

<H4.0 Carbon
ciclo cross

Disponibile in versione Carbon H5.4 speed
(40 mm ant. - 55 mm post.) - Versione Professional

Available as version Carbon H5.4 speed
(40 mm front - 55 mm rear) - Professional Version

Autorizzato U.C.I. - Authorized from U.C.I.
Certificato a norme UNI.CE.EN 14781
Certified to norm UNI.CE.EN 14781

<PROFILE

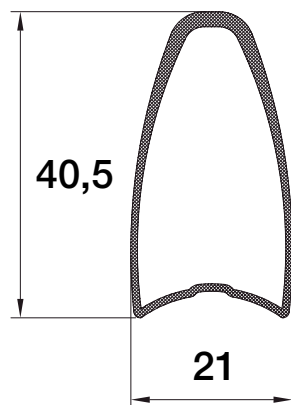
<H4.0 Carbon
tubolare

Autorizzato U.C.I. - Authorized from U.C.I.
Certificato a norme UNI.CE.EN 14781
Certified to norm UNI.CE.EN 14781

<PROFILE

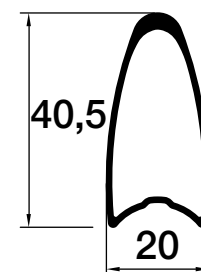

| | | | |
|-----------|---|----------|-------------------|
| MODELLO | Tubolare 28" 700 C | | |
| ETRTO | 632-22 din | O.L.D. | 100/130 |
| VERSIONI | Campagn.-Shimano-Sram | FINITURA | Fibra di carbonio |
| CERCHIO | Monoscocca 100% fibra di carbonio alto 40 mm - foro valvola 6.5 mm | | |
| RAGGI | Sapim CXRay 20 inox aero sfinati - post. inc. x 2 ant. radiali | | |
| NIPPLES | Autobloccanti ABS L 13 in Ergal con rondelle | | |
| MOZZI | Versione GPMCHlight, alluminio forgiato, cassetta Ergal su cuscinetti | | |
| BLOCCAGGI | Alluminio forgiato peso al paio 110 gr | | |
| PESO | Ant. 550 gr. - Post. 710 gr. - Tot. 1260 gr. (+/- 7% senza bloccaggi) | | |

| | | | |
|----------|---|--------|--------------|
| MODEL | Tubular 28" 700 C | | |
| ETRTO | 632-20 din O.L.D. | O.L.D. | 100/130 |
| VERSIONS | Campagn.-Shimano-Sram | FINISH | Carbon fiber |
| RIM | 100% carbon fiber monocoque height 40 mm - valve hole 6.5 mm | | |
| SPOKES | Sapim CXRay 20 stainless steel aero-spoke, double size Front radial, 24 Rear cross by 2 | | |
| NIPPLES | Self-locking ABS L 13 Ergal with washers | | |
| HUB | GPMCHlight forged aluminium with Ergal cassette on sealed bearings | | |
| Q.R. | Forged aluminium - weight 110 gr. | | |
| WEIGHT | Front 550 gr. - Rear 710 gr. Tot. 1260 gr. (+/- 7% without quick release) | | |

| | | | |
|-----------|---|----------|-------------------|
| MODELLO | Tubolare 28" 700 C | | |
| ETRTO | 632-20 din | O.L.D. | 100/130 |
| VERSIONI | Campagn.-Shimano-Sram | FINITURA | Fibra di carbonio |
| CERCHIO | Monoscocca 100% fibra di carbonio alto 40 mm - foro valvola 6.5 mm | | |
| RAGGI | Sapim CXRay 20 inox aero sfinati - post. inc. x 2 ant. radiali | | |
| NIPPLES | Autobloccanti ABS L 13 in Ergal con rondelle | | |
| MOZZI | Versione GPMCHlight, alluminio forgiato, cassetta Ergal su cuscinetti | | |
| BLOCCAGGI | Alluminio forgiato peso al paio 110 gr | | |
| PESO | Ant. 550 gr. - Post. 710 gr. - Tot. 1260 gr. (+/- 7% senza bloccaggi) | | |

| | | | |
|----------|---|--------|--------------|
| MODEL | Tubular 28" 700 C | | |
| ETRTO | 632-20 din | O.L.D. | 100/130 |
| VERSIONS | Campagn.-Shimano-Sram | FINISH | Carbon fiber |
| RIM | 100% carbon fiber monocoque height 40 mm - valve hole 6.5 mm | | |
| SPOKES | Sapim CXRay 20 stainless steel aero-spoke, double size Front radial, 24 Rear cross by 2 | | |
| NIPPLES | Self-locking ABS L 13 Ergal with washers | | |
| HUB | GPMCHlight forged aluminium with Ergal cassette on sealed bearings | | |
| Q.R. | Forged aluminium - weight 110 gr. | | |
| WEIGHT | Front 550 gr. - Rear 710 gr. Tot. 1260 gr. (+/- 7% without quick release) | | |

<UTILIZATION

- Road** ●●●●●●
- Chrono** ●●●●
- Cyclocross** ●
- Track**

Book
2013

<UTILIZATION

- Road** ●●●●●●
- Chrono** ●●●●
- Cyclocross** ●●●●●
- Track**

<H4.0 Carbon
speed

Certificato a norme UNI.CE.EN 14781
Certified to norm UNI.CE.EN 14781
Autorizzato U.C.I. - Authorized from U.C.I.

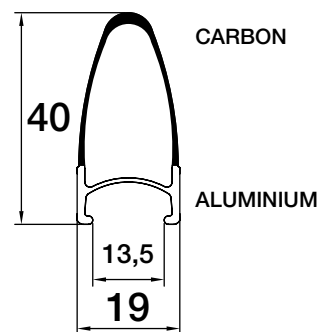

<PROFILE

<H2.5 Carbon
tubolare

RISPETTA NORME UCI - UNDER UCI RULE



<PROFILE

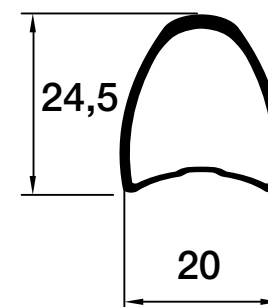

| | | | |
|-----------|---|----------|-------------------|
| MODELLO | Copertoncino 28" 700 C | | |
| ETRTO | 622-13,5 din | O.L.D. | 100/130 |
| VERSIONI | Campagn.-Shimano-Sram | FINITURA | Fibra di carbonio |
| CERCHIO | Carbonio strutturale e alluminio 6082-T6 saldato, forato CNC, foro valvola 6.5 mm | | |
| RAGGI | Sapim CXRay 20 inox aero sfinati - post. dx inc. x 2, sx e ant. radiali | | |
| NIPPLES | Autobloccanti ABS L 13 in Ergal con rondelle | | |
| MOZZI | Versione GPMCHlight, alluminio forgiato, cassetta Ergal su cuscinetti | | |
| BLOCCAGGI | Alluminio forgiato peso al paio 110 gr | | |
| PESO | Ant. 712 gr. - Post. 883 gr. Tot. 1595 gr. (+/- 7% senza bloccaggi) | | |

| | | | |
|----------|---|--------|--------------|
| MODEL | Clincher 28" 700 C | | |
| ETRTO | 622-13,5 din | O.L.D. | 100/130 |
| VERSIONS | Campagn.-Shimano-Sram | FINISH | Carbon fiber |
| RIM | Structural carbon fiber with aluminium 6082-T6 welded, CNC holes, valve hole 6.5 mm | | |
| SPOKES | Sapim CXRay 20 stainless steel aero spokes double size, Front and rear left radial, Rear cross by 2 | | |
| NIPPLES | Self-locking ABS L 13 Ergal with washers | | |
| HUB | GPMCHlight forged aluminium with Ergal cassette on sealed bearings | | |
| Q.R. | Forged aluminium - weight 110 gr. | | |
| WEIGHT | Front 712 gr. - Rear 883 gr. Tot. 1595 gr. (+/- 7% without quick release) | | |

| | | | |
|-----------|--|----------|-------------------|
| MODELLO | Tubolare 28" 700C | | |
| ETRTO | 632-20din | O.L.D. | 100/130 |
| VERSIONI | Campagn.-Shimano-Sram | FINITURA | Fibra di carbonio |
| CERCHIO | Monoscocca 100% fibra di carbonio alto 24.5mm - foro valvola 6,5mm | | |
| RAGGI | Sapim Cx-ray 20 Inox aero sfinati - Post. Inc x2 DX x1 SX Ant. Radiali | | |
| NIPPLES | Autobloccanti ABS L13 in Ergal con rondelle | | |
| MOZZI | Versione GMCHlight, Alluminio forgiato, Cassetta Ergal su cuscinetti | | |
| BLOCCAGGI | Alluminio forgiato peso al paio 110gr | | |
| PESO | 470gr. Post 625gr. - Tot. 1095 Gr (+/-7% senza bloccaggi) | | |

| | | | |
|----------|---|--------|--------------|
| MODEL | Tubular 28" 700C | | |
| ETRTO | 632-20 din | O.L.D. | 100/130 |
| VERSIONS | Campagn.-Shimano-Sram | FINISH | Carbon fiber |
| RIM | 100% carbon fiber monocoque height 24.5 mm - valve 6,5 mm | | |
| SPOKES | Sapim Cx-Ray nr.20 Innox aero double size - Front Radial / Rear cross by 2 DX by 1 SX | | |
| NIPPLES | Self locking ABS L13 Ergal | | |
| HUB | GPMCHlight Forged aluminium - Ergal cassette on seal bearings | | |
| Q.R. | Forged aluminium - weight 110 gr. | | |
| WEIGHT | Front 470gr. - Rear 625gr. Tot. 1095gr. (+/- 7% with out quick release) | | |

<UTILIZATION

- Road** ●●●●●●
- Chrono** ●●●
- Cyclocross** ●
- Track**

Book
2013

<UTILIZATION

- Road** ●●●●●●
- Chrono** ●●
- Cyclocross** ●●
- Track**

<H2.5 Carbon
speed

RISPETTA NORME UCI - UNDER UCI RULE

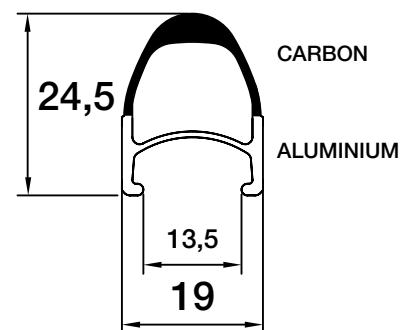

<PROFILE

<1.55 Tecno
ultralightAuthorized from U.C.I.
Certified to norm UNI.CE.EN 14781

<PROFILE

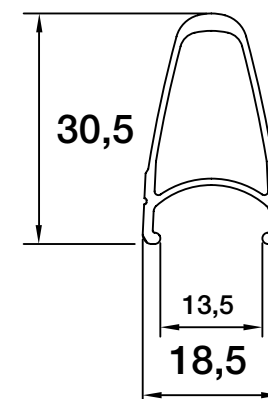

| | | | |
|-----------|---|----------|-------------------|
| MODELLO | Copertoncino 28" 700 C | | |
| ETRTO | 622-13,5 din | O.L.D. | 100/130 |
| VERSIONI | Campagn.-Shimano-Sram | FINITURA | Fibra di carbonio |
| CERCHIO | Carbonio strutturale e alluminio 6082-T6 saldato, forato CNC, foro valvola 6.5 mm | | |
| RAGGI | Sapim CXRay 20/24 inox aero sfinati - post. dx inc. x 2, sx e ant. radiali | | |
| NIPPLES | Autobloccanti ABS L 13 in Ergal con rondelle | | |
| MOZZI | Versione GPMCHlight, alluminio forgiato, cassetta Ergal su cuscinetti | | |
| BLOCCAGGI | Alluminio forgiato peso al paio 110 gr | | |
| PESO | Ant. 625 gr. - Post. 770 gr. Tot. 1395 gr. (+/- 7% senza bloccaggi) | | |

| | | | |
|----------|---|--------|--------------|
| MODEL | Clincher 28" 700 C | | |
| ETRTO | 622-13,5 din | O.L.D. | 100/130 |
| VERSIONS | Campagn.-Shimano-Sram | FINISH | Carbon fiber |
| RIM | Structural carbon fiber with aluminium 6082-T6 welded, CNC holes, valve hole 6.5 mm | | |
| SPOKES | Sapim CXRay 20/24 stainless steel aero spokes double | | |
| NIPPLES | Self-locking ABS L 13 Ergal with washers | | |
| HUB | GPMCHlight forged aluminium with Ergal cassette on sealed bearings | | |
| Q.R. | Forged aluminium - weight 110 gr. | | |
| WEIGHT | Front 625 gr. - Rear 770 gr. Tot. 1395 gr. (+/- 7% without quick release) | | |

| | | | |
|-----------|---|----------|------------------------|
| MODELLO | Copertoncino 28" 700 C | | |
| ETRTO | 622-13,5 din | O.L.D. | 100/130 |
| VERSIONI | Campagn.-Shimano-Sram | FINITURA | Nero/Silver anodizzato |
| CERCHIO | Alluminio 6082-T6 saldato, forato a CNC, foro valvola 6.5 mm | | |
| RAGGI | Sapim CXRay 20 inox aero sfinato Post. inc.x2 - Ant. inc.x1 | | |
| NIPPLES | Autobloccanti ABS L 13 in Ergal con rondelle | | |
| MOZZI | Versione GPMCHlight, alluminio forgiato, cassetta Ergal su cuscinetti | | |
| BLOCCAGGI | Alluminio forgiato peso al paio 110 gr | | |
| PESO | Ant. 652 gr. - Post. 809 gr. Tot. 1461 gr. (+/- 5% senza bloccaggi) | | |

| | | | |
|----------|---|--------|-----------------------|
| MODEL | Clincher 28" 700 C | | |
| ETRTO | 622-13,5 din | O.L.D. | 100/130 |
| VERSIONS | Campagn.-Shimano-Sram | FINISH | Black/Silver Anodized |
| RIM | Aluminium welded 6082-T6, CNC holes, valve hole 6.5 mm | | |
| SPOKES | Sapim CXRay 20 stainless steel aero spokes double size, Rear cross by 2, Front cross by 1 | | |
| NIPPLES | Self-locking ABS L 13 Ergal with washers | | |
| HUB | GPMCHlight forged aluminium with Ergal cassette on sealed bearings | | |
| Q.R. | Forged aluminium - weight 110 gr. | | |
| WEIGHT | Front 652 gr. - Rear 809 gr. Tot. 1461 gr. (+/- 5% without quick release) | | |



<UTILIZATION

- Road** ●●●●●●
- Chrono** ●●●●●●
- Cyclocross** ●●●●●●
- Track**

Book
2013

<UTILIZATION

- Road** ●●●●●●
- Chrono** ●●●●●●
- Cyclocross**
- Track**

<Krono
ultralight

Autorizzato U.C.I. - Authorized from U.C.I.
Certificato a norme UNI.CE.EN 14781
Certified to norm UNI.CE.EN 14781

<PROFILE

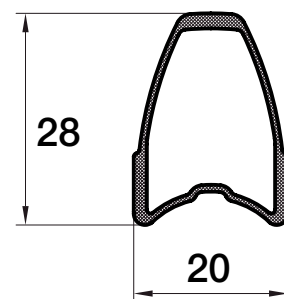

| | | | |
|-----------|--|----------|----------------------------------|
| MODELLO | Tubolare 28" 700 C | | |
| ETRTO | 632-19 din | O.L.D. | 100/130 |
| VERSIONI | Campagn.-Shimano-Sram | FINITURA | Anodizzata nera/silver con laser |
| CERCHIO | Alluminio 6082-T6 saldato, forato a CNC, foro valvola 6.5 mm | | |
| RAGGI | Sapim CXRay 20 inox aero Sfi nati - Ant. radiali - Post. dx inc. x 1, sx radiale | | |
| NIPPLES | Autobloccanti ABS L 13 in Ergal con rondelle | | |
| MOZZI | versione GPCHlight, alluminio forgiato, cassetta Ergal su cuscinetti | | |
| BLOCCAGGI | Alluminio forgiato peso al paio 110 gr | | |
| PESO | Ant. 630 gr. - Post. 800 gr. Tot. 1420 gr. (+/- 5% senza bloccaggi) | | |

| | | | |
|----------|--|--------|---------------------------|
| MODEL | Tubular 28" 700 C | | |
| ETRTO | 632-19 din | O.L.D. | 100/130 |
| VERSIONS | Campagn.-Shimano-Sram | FINISH | Anodized black with laser |
| RIM | Aluminium welded 6082-T6, CNC holes, valve hole 6.5 mm | | |
| SPOKES | Sapim CXRay 20 stainless steel aero-spoke, double size Front radial, Rear cross by 2 | | |
| NIPPLES | Self-blocking ABS L 13 Ergal with washers | | |
| HUB | GPMCHlight forged aluminium with Ergal cassette on sealed bearings | | |
| Q.R. | Forged aluminium - weight 110 gr. | | |
| WEIGHT | Front 630 gr. - Rear 800 gr. Tot. 1420 gr. (+/- 5% without quick release) | | |

<Equipe 716

Autorizzato U.C.I. - Authorized from U.C.I.
Certificato a norme UNI.CE.EN 14781
Certified to norm UNI.CE.EN 14781

COLORI/COLOR

Bianco/White Nero/Black

<PROFILE

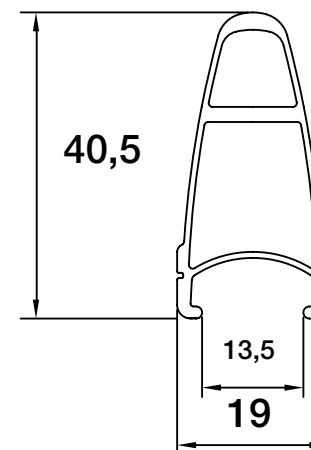

| | | | |
|-----------|---|----------|---|
| MODELLO | Copertoncino 28" 700 C | | |
| ETRTO | 622-13,5 din | O.L.D. | 100/130 |
| VERSIONI | Campagn.-Shimano-Sram | FINITURA | Verniciato Nero Bianco con etichette |
| CERCHIO | Trecamere, alto 40mm alluminio 6082-T6 Spinato e saldato, Forato a CNC 3D, foro valvola 6,5mm | | |
| RAGGI | Sapim Inox piatti Ant. nr 16 T2 (8x2) - Post. Nr 20 T2 (10x2) | | |
| NIPPLES | Autobloccanti ABS L12 | | |
| MOZZI | Alluminio forgiato, Cassetta Ergal su cuscinetti | | |
| BLOCCAGGI | Alluminio forgiato peso al paio 110gr | | |
| PESO | Ant. 940gr. Post 1158gr. - Tot. 2049gr (+/-5% senza bloccaggi) | | |

| | | | |
|----------|---|--------|---|
| MODEL | Clincher 28" 700 C | | |
| ETRTO | 622-13,5 din | O.L.D. | 100/130 |
| VERSIONS | Campagn.-Shimano-Sram | FINISH | Black anodize / white paint with sticker |
| RIM | Three-wall 40mm high. Aluminium pin-welded 6082-T6, CNC holes 3D valve 6,5 mm | | |
| SPOKES | Sapim front 16 T2(8x2) Rear nr.20 (10x2) | | |
| NIPPLES | Self-Locking ABS L12 | | |
| HUB | Forged aluminium - Ergal cassette on seal bearings | | |
| Q.R. | Forged aluminium - weight 110 gr. | | |
| WEIGHT | Front 940gr. - Rear 1158gr. Tot. 2049gr. (+/- 5% with out quick release) | | |



<UTILIZATION

- Road** ●●●●●●
- Chrono** ●●●●●●
- Cyclocross** ●
- Track**

Book
2013

<UTILIZATION

- Road** ●●●●●●
- Chrono** ●●
- Cyclocross**
- Track**

<Tecno 716
light

Autorizzato U.C.I. - Authorized from U.C.I.
Certificato a norme UNI.CE.EN 14781
Certified to norm UNI.CE.EN 14781

<PROFILE

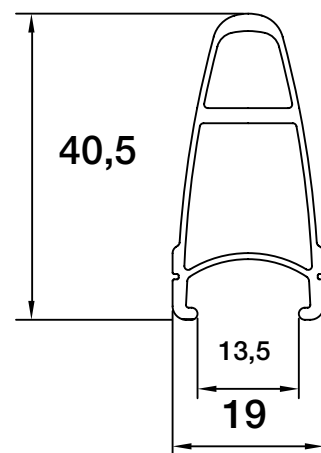

| | | | |
|-----------|---|----------|---------------------------|
| MODELLO | Copertoncino 28" 700 C | | |
| ETRTO | 622-13.5 din | O.L.D. | 100/130 |
| VERSIONI | Campagn.-Shimano-Sram | FINITURA | Anodizzata nera con laser |
| CERCHIO | Trecamere, alto 40mm alluminio 6082-T6 saldato, Forato a CNC 3D, foro valvola 6,5mm | | |
| RAGGI | Sapim Cx-ray 20 Inox aero sfinati - Post. Inc x2 Ant. Radiali | | |
| NIPPLES | Autobloccanti ABS L13 in Ergal con rondelle | | |
| MOZZI | Versione GPMCHlight, Alluminio forgiato, Cassetta Ergal su cuscinetti | | |
| BLOCCAGGI | Alluminio forgiato peso al paio 110gr | | |
| PESO | Ant. 795gr. Post 955gr. - Tot. 1750Gr (+/-5% senza bloccaggi) | | |

| | | | |
|----------|--|--------|--------------------------|
| MODEL | clincher 28" 700C | | |
| ETRTO | 622-13,5 din | O.L.D. | 100/130 |
| VERSIONS | Campagn.-Shimano-Sram | FINISH | Black anodize with laser |
| RIM | Three-wall 40mm high. Aluminium weld 6082-T6, CNC holes 3D valve 6,5 mm | | |
| SPOKES | Sapim Cx-ray nr.20 stainless steel aero-spoke, double size front radial, rear Inc.X2 | | |
| NIPPLES | Self locking ABS L13 Ergal with washers | | |
| HUB | GPMCHlight, Forged aluminium - Ergal cassette on seal bearings | | |
| Q.R. | Forged aluminium - weight 110 gr. | | |
| WEIGHT | Front 795gr. - Rear 955gr. Tot. 1750gr. (+/- 5% with out quick release) | | |

<Tecno 1.55
equipe

Autorizzato U.C.I. - Authorized from U.C.I.
Certificato a norme UNI.CE.EN 14781
Certified to norm UNI.CE.EN 14781

COLORI/COLOR

Bianco/White Nero/Black

<PROFILE

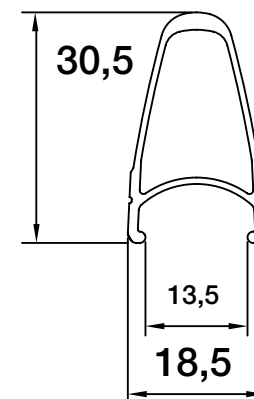

| | | | |
|-----------|---|----------|------------------------|
| MODELLO | Copertoncino 28" 700 C | | |
| ETRTO | 622-13,5 din | O.L.D. | 100/130 |
| VERSIONI | Campagn.-Shimano-Sram | FINITURA | Verniciata nera/bianca |
| CERCHIO | Alluminio 6082-T6 saldato, forato a CNC, foro valvola 6.5 mm | | |
| RAGGI | Sapim 20 piatti inox - Ant. radiali - Post. radiali e inc. x 1 | | |
| NIPPLES | Autobloccanti ABS L 12 | | |
| MOZZI | GPMJ alluminio forgiato cassetta Ergal su cuscinetti | | |
| BLOCCAGGI | Alluminio forgiato peso al paio 116 gr | | |
| PESO | Ant. 744 gr. - Post. 921 gr. Tot. 1665 gr. (+/- 5% senza bloccaggi) | | |

| | | | |
|----------|---|--------|-------------------|
| MODEL | Clincher 28" 700 C | | |
| ETRTO | 622-13,5 din | O.L.D. | 100/130 |
| VERSIONS | Campagn.-Shimano-Sram | FINISH | White/black paint |
| RIM | Aluminium welded 6082-T6, CNC holes, valve hole 6,5 mm | | |
| SPOKES | 20 inox sapin aero spokes, Front radial - Rear cross by 1 and radial | | |
| NIPPLES | Self-locking ABS L 12 | | |
| HUB | GPMJ forged aluminium with Ergal cassette on sealed bearings | | |
| Q.R. | Forged aluminium - weight 116 gr. | | |
| WEIGHT | Front 744 gr. - Rear 921 gr. Tot. 1665 gr. (+/- 5% without quick release) | | |



- <UTILIZATION
- track
 - road
 - bike polo
 - freestyle

Book 2013



- <UTILIZATION
- track
 - road
 - bike polo
 - freestyle



<Manta pista



<PROFILE

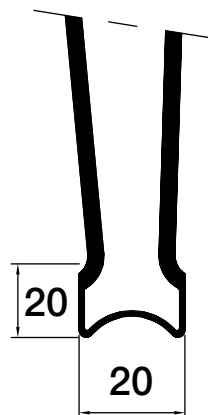

<Pista H6.0



<PROFILE

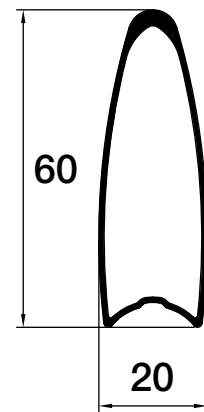

| | | | |
|-----------|--|----------|-------------------|
| MODELLO | Tubolare 28" 700 C | | |
| ETRTO | 632-20 din | O.L.D. | 100/120 |
| VERSIONI | Pista | FINITURA | Fibra di carbonio |
| CERCHIO | 100% fibra di carbonio foro valvola 6.5 mm | | |
| RAGGI | N/P | | |
| NIPPLES | N/P | | |
| MOZZI | Alluminio Ergal su cuscinetti | | |
| BLOCCAGGI | N/P | | |
| PESO | Ant. 1078 gr. - Post. 1225 gr. (+/- 7%) | | |

| | | | |
|----------|---|--------|--------------|
| MODEL | Tubular 28" 700 C | | |
| ETRTO | 632-20 din | O.L.D. | 100/120 |
| VERSIONS | Track | FINISH | Carbon fiber |
| RIM | 100% carbon fiber monocoque valve hole 6.5 mm | | |
| SPOKES | N/P | | |
| NIPPLES | N/P | | |
| HUB | Aluminium Ergal with sealed bearings | | |
| Q.R. | N/P | | |
| WEIGHT | Front 1078 gr. - Rear 1225 gr. (+/- 7%) | | |

| | | | |
|-----------|---|----------|-------------------|
| MODELLO | Tubolare 28" 700 C | | |
| ETRTO | 632-20 din | O.L.D. | 100/120 |
| VERSIONI | Pista/Pista | FINITURA | Fibra di carbonio |
| CERCHIO | Monoscocca 100% fibra di carbonio - foro valvola 6.5 mm | | |
| RAGGI | Inox 20 ant./ Post. inc. x 2 | | |
| NIPPLES | Autobloccanti ABS L 13 con rondelle | | |
| MOZZI | Alluminio forgiato, su cuscinetti | | |
| BLOCCAGGI | N/P | | |
| PESO | Ant. 862 gr. - Post. 912 gr. - Tot. 1774 gr. (+/- 7% senza bloccaggi) | | |

| | | | |
|----------|---|--------|--------------|
| MODEL | Tubular 28" 700 C | | |
| ETRTO | 632-20 din | O.L.D. | 100/120 |
| VERSIONS | Track T/T | FINISH | Carbon fiber |
| RIM | 100% carbon fiber monocoque valve hole 6.5 mm | | |
| SPOKES | 20 stainless steel Front, 24 Rear cross by 2 | | |
| NIPPLES | Self-locking ABS L 13 with washers | | |
| HUB | Forged aluminium with sealed bearings | | |
| Q.R. | N/P | | |
| WEIGHT | Front 862 gr. - Rear 912 gr. Tot. 1774 gr. (+/- 7%) | | |



<UTILIZATION

- Track** ●●●●●
- Road** ●●●●●
- Bike polo** ●●●●●
- Freestyle** ●●●●●

Book
2013

<UTILIZATION

- Pista A40
- Track** ●●●●●
- Road** ●●●●●
- Bike polo** ●●●●●
- Freestyle** ●●●●●

- Pista A40 fixed
- Track** ●●●●●
- Road** ●●●●●
- Bike polo** ●●●●●
- Freestyle** ●●●●●

<K28
pista tubolare

<PROFILE

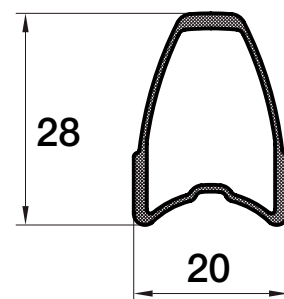
<Pista A40
<Pista A40 fixed

COLORI/COLOR

- Nero/Black
- Argento/Silver
- Giallo/Yellow
- Arancio/Orange
- Viola/Violet
- Canna di fucile/Black Gun
- Bronzo/Bronze



Disponibile W-Brake

<PROFILE

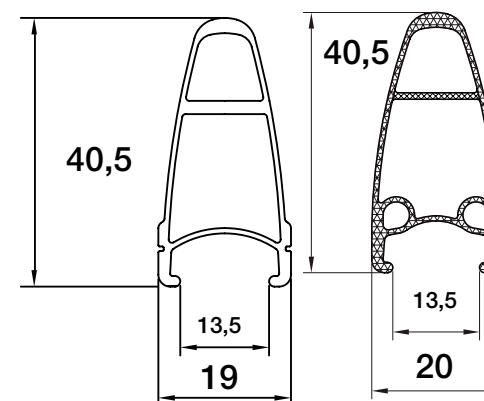

| | | | |
|-----------|---|----------|----------------------------|
| MODELLO | Tubolare 28" 700 C | | |
| ETRTO | 632-20 din | O.L.D. | 100/130 |
| VERSIONI | Pista/Pista | FINITURA | Anodizzata nera/ con laser |
| CERCHIO | Alluminio 6082-T6 saldato, forato a CNC, foro valvola 6.5 mm | | |
| RAGGI | 20 Sapim Inox ant./ Post. inc. x 2 | | |
| NIPPLES | Autobloccanti ABS L 13 con rondelle | | |
| MOZZI | Alluminio forgiato, su cuscinetti | | |
| BLOCCAGGI | N/P | | |
| PESO | Ant. 913 gr. - Post. 972 gr. Tot. 1885 gr. (+/- 5% senza bloccaggi) | | |

| | | | |
|----------|---|--------|---------------------------|
| MODEL | Tubular 28" 700 C | | |
| ETRTO | 632-20 din | O.L.D. | 100/130 |
| VERSIONS | Track T/T | FINISH | Anodized black with laser |
| RIM | Aluminium welded 6082-T6, CNC holes, valve hole 6.5 mm | | |
| SPOKES | 20 Sapim stainless steel Front, 24 Rear cross by 2 | | |
| NIPPLES | Self-locking ABS L 13 with washers | | |
| HUB | Forged aluminium with sealed bearings | | |
| Q.R. | N/P | | |
| WEIGHT | Front 913 gr. - Rear 972 gr. Tot. 1885 gr. (+/- 5% without quick release) | | |

| | | | |
|-----------|---|----------|--|
| MODELLO | Copertoncino 28" 700 C | | |
| ETRTO | 622-13,5 din | O.L.D. | 100/120 |
| VERSIONI | P/P o P/RL | FINITURA | Polish anodizzato silver/Vern. nero o bianco |
| CERCHIO | Alluminio 6005-T6, foro valvola 7 mm | | |
| RAGGI | Inox 32 Ant./ Post. inc. x 3 | | |
| NIPPLES | L 13 mm | | |
| MOZZI | Alluminio forgiato, su cuscinetti | | |
| BLOCCAGGI | N/P | | |
| PESO | Ant. 1240 gr. - Post. 1290 gr. Tot. 2530 gr. (+/- 5%) | | |

| | | | |
|----------|---|--------|---|
| MODEL | Clincher 28" 700 C | | |
| ETRTO | 622-13,5 din | O.L.D. | 100/120 |
| VERSIONS | T/T o T/FW | FINISH | silver Polish anodized black or white Point |
| RIM | Aluminium 6005-T6, valve hole 7 mm | | |
| SPOKES | 32 stainless steel Front / Rear cross by 3 | | |
| NIPPLES | L 13 mm | | |
| HUB | Forged aluminium with sealed bearings | | |
| Q.R. | N/P | | |
| WEIGHT | Front 1240 gr. - Rear 1290 gr. Tot. 2530 gr. (+/- 5%) | | |

<UTILIZATION

- t**rack ●●●
- r**oad ●●●
- b**ike polo ●●
- f**reestyle ●

Book
2013

<UTILIZATION

- t**rack ●●●
- r**oad ●●●
- b**ike polo ●●●
- f**reestyle ●

<Pista
street

COLORI/COLOR

□ Bianco/White ■ Nero/Black



<PROFILE

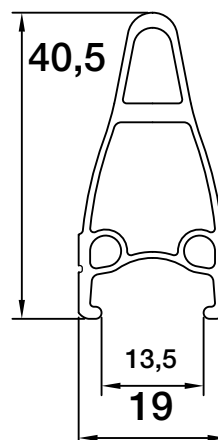

<Pista 030

DISPONIBILE V-BRAKE
AVAILABLE V-BRAKE

COLORI/COLOR

■ Silver Brill
■ Nero/Black
□ Bianco/White



<PROFILE

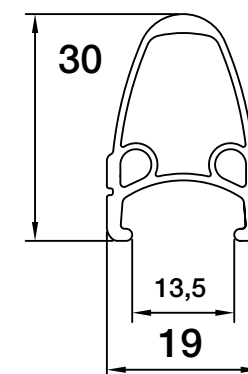

| | | | |
|-----------|---|----------|------------------------|
| MODELLO | Copertoncino 28" 700 C | | |
| ETRTO | 622-13,5 din | O.L.D. | 100/120 |
| VERSIONI | P/P o P/RL | FINITURA | Verniciato Nero/Bianco |
| CERCHIO | alluminio 6082-T6 lavorato a CNC foro valvola 7 mm | | |
| RAGGI | Inox 20 | | |
| NIPPLES | Ottone L 25mm | | |
| MOZZI | Alluminio forgiato, su cuscinetti | | |
| BLOCCAGGI | N/P | | |
| PESO | Ant. 1051 gr. - Post. 1105 gr. Tot. 2156 gr. (+/- 5%) | | |

| | | | |
|----------|---|--------|-------------------|
| MODEL | Clincher 28" 700 C | | |
| ETRTO | 622-13,5 din | O.L.D. | 100/120 |
| VERSIONS | T/T o T/FW | FINISH | Black/white paint |
| RIM | Aluminium 6082 T6, valve worked by CNC. Hole 7 mm | | |
| SPOKES | 20 Stainless steel | | |
| NIPPLES | Brass 25mm | | |
| HUB | Forged aluminium with sealed bearings | | |
| Q.R. | N/D | | |
| WEIGHT | Front 1051 gr. - Rear 1105 gr. Tot. 2156 gr. (+/- 5%) | | |

| | | | |
|-----------|---|----------|-------------------------------------|
| MODELLO | Copertoncino 28" 700 C | | |
| ETRTO | 622-13,5 din | O.L.D. | 100/120 |
| VERSIONI | P/P o P/RL | FINITURA | Brillatato/Verniciato Nero o Bianco |
| CERCHIO | Alluminio 6005-T6, foro valvola 7 mm | | |
| RAGGI | Inox 32 Ant./ Post. inc. x 3 | | |
| NIPPLES | L 13 mm | | |
| MOZZI | Alluminio forgiato, su cuscinetti | | |
| BLOCCAGGI | N/P | | |
| PESO | Ant. 1104 gr. - Post. 1156 gr. Tot. 2260 gr. (+/- 5%) | | |

| | | | |
|----------|---|--------|-------------------------------------|
| MODEL | Clincher 28" 700 C | | |
| ETRTO | 622-13,5 din | O.L.D. | 100/120 |
| VERSIONS | T/T o T/FW | FINISH | Silver Brill / Black or white paint |
| RIM | Aluminium 6005-T6, valve hole 7 mm | | |
| SPOKES | 32 stainless steel Front / Rear cross by 3 | | |
| NIPPLES | L 13 mm | | |
| HUB | Forged aluminium with sealed bearings | | |
| Q.R. | N/P | | |
| WEIGHT | Front 1104 gr. - Rear 1156 gr. Tot. 2260 gr. (+/- 5%) | | |



<UTILIZATION

- Track**
- Road** ●●●
- Bike polo** ●●●●
- Freestyle**

Book
2013

<UTILIZATION

- Xc** ●●●●●
- Marathon** ●●●
- Trail** ●●
- Crossmountain** ●
- Enduro**

<Pista
fixedDISPONIBILE V-BRAKE
AVAILABLE V-BRAKE

COLORI/COLOR

- Silver
- Nero/Black
- Bianco/White

<PROFILE

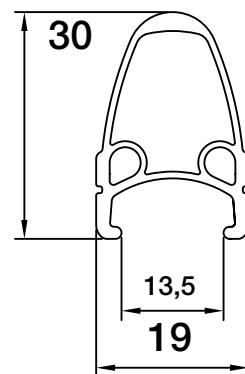
<Sierra CX
tubolare

OPTIONAL:

- Lefty Option
- 15 mm
- 20 mm Axel

<PROFILE

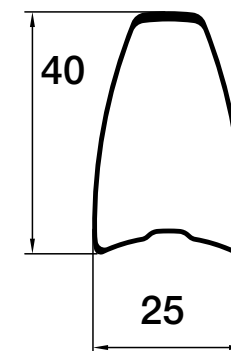

| | | | |
|-----------|---|----------|--------------------------|
| MODELLO | Copertoncino 28" 700 C | | |
| ETRTO | 622-13,5 din | O.L.D. | 100/120 |
| VERSIONI | Pista /Ruota Libera | FINITURA | Verniciato nero o bianco |
| CERCHIO | Alluminio 6005-T6, foro valvola 7 mm | | |
| RAGGI | 32 neri | | |
| NIPPLES | L 13 mm | | |
| MOZZI | Alluminio forgiato su sfere | | |
| BLOCCAGGI | N/P | | |
| PESO | Ant. 1159 gr. - Post. 1230 gr. Tot. 2389 gr. (+/- 5%) | | |

| | | | |
|----------|---|--------|----------------------|
| MODEL | Clincher 28" 700 C | | |
| ETRTO | 622-13,5 din | O.L.D. | 100/120 |
| VERSIONS | Track/FreeWheels | FINISH | Black or white paint |
| RIM | Aluminium 6005-T6, valve hole 7 mm | | |
| SPOKES | 32 black | | |
| NIPPLES | L 13 mm | | |
| HUB | Forged alloy on lose ball | | |
| Q.R. | N/P | | |
| WEIGHT | Front 1159 gr. - Rear 1230 gr. Tot. 2389 gr. (+/- 5%) | | |

| | | | |
|-----------|---|----------|-------------------|
| MODELLO | Tubolare 26" mtb | | |
| ETRTO | 571-25 din | O.L.D. | 100/135 |
| VERSIONI | Shimano | FINITURA | Fibra di carbonio |
| CERCHIO | Monoscocca 100% fibra di carbonio alto 40 mm - foro valvola 6.5 mm | | |
| RAGGI | Sapim CXRay Inox aero sfinati - 24 ant. / 24 post. inc. x 2 | | |
| NIPPLES | Autobloccanti ABS L 13 in Ergal con rondelle | | |
| MOZZI | Versione GPMCHMTBDisc, alluminio forgiato, cassetta Ergal su cuscinetti | | |
| BLOCCAGGI | Alluminio forgiato peso al paio 110 gr | | |
| PESO | Ant. 625 gr. - Post. 710 gr. Tot. 1335 gr. (+/- 7% senza bloccaggi) | | |

| | | | |
|----------|---|--------|--------------|
| MODEL | Tubular 26" mtb | | |
| ETRTO | 571-25 din | O.L.D. | 100/135 |
| VERSIONS | Shimano | FINISH | Carbon fiber |
| RIM | 100% carbon fiber monocoque height 40 mm, valve hole 6.5 mm | | |
| SPOKES | Sapim CXRay 24 F/24 R, stainless steel aero-spoke, double size Front /Rear cross by 2 | | |
| NIPPLES | Self-locking ABS L 13 Ergal with washers | | |
| HUB | GPMCHMTBDisc, forged aluminium with Ergal cassette on sealed bearings | | |
| Q.R. | Forged aluminium - weight 110 gr. | | |
| WEIGHT | Front 625 gr. - Rear 710 gr. Tot. 1335 gr. (+/- 7% without quick release) | | |



<UTILIZATION

Tubolare/Tubular

- xc** ●●●●●●
- marathon** ●●●●●●
- trail** ●●
- CROSSmountain** ●
- Enduro** ●

Tubeless/Clincher

- xc** ●●●●●●
- marathon** ●●●●●●
- trail** ●●●●
- CROSSmountain** ●●
- Enduro** ●



<UTILIZATION

Tubolare/Tubular

- xc** ●●●●●●
- marathon** ●●●●●●
- trail** ●●
- CROSSmountain** ●
- Enduro** ●

Tubeless/Clincher

- xc** ●●●●●●
- marathon** ●●●●●●
- trail** ●●●●
- CROSSmountain** ●●
- Enduro** ●●

<Kenya 29" 26"

ultralight

Disponibile Tubular / Tubeless

OPTIONAL:

- Lefty Option
- 15 mm
- 20 mm Axel

<PROFILE

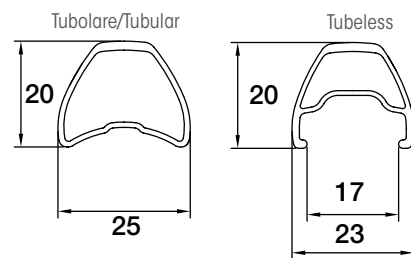

26" Tubeless/ Copertoncino/Tubolare

PESO: Ant. 620 gr. - Post. 770 gr. Tot. 1390 gr.
 (+/- 5% senza bloccaggi e liquido GIPIEMME sealant)
 ETRTO: Tubol. 571-25din/Tubel. 559-17din O.L.D. 100/135
 RAGGI: Sapim laser 24 inox aero sfinati double size

29" Tubeless/ Copertoncino/Tubolare

PESO: nt. 750 gr. - Post. 893 gr. 1642 Tot. gr.
 (+/- 5% senza bloccaggi e liquido GIPIEMME sealant)
 ETRTO: Tubol. 632-25din/Tubel. 622-17din O.L.D. 100/135
 RAGGI: Sapim laser 32 inox aero sfinati ouble size

| | | |
|-----------|--|------------------------------------|
| MODELLO | 26" 29" mtb Tubolare/Tubeless | |
| VERSIONI | Shimano | FINITURA Anodizzata nera con laser |
| CERCHIO | Alluminio 6082-T6 saldato, foro valvola 6.5 mm | |
| NIPPLES | Autobloccanti ABS L 13 in ergal | |
| MOZZI | Versione GPMKCHMTBDisc, alluminio forgiato, cassetta Ergal su cuscinetti | |
| BLOCCAGGI | Alluminio forgiato peso al paio 110 gr | |

| | | |
|----------|--|----------------------------------|
| MODEL | Clincher Tubular/Tubeless 26" 29" mtb | |
| VERSIONS | Shimano | FINISH Black anodized with laser |
| RIM | Aluminium welded 6082-T6, valve hole 6.5 mm | |
| NIPPLES | Self-blocking ABS L 13 Ergal | |
| HUB | GPMKCHMTBDisc, forged aluminium with Ergal cassette on sealed bearings | |
| Q.R. | Forged aluminium - weight 110 gr. | |

<Kenya 27,5"

ultralight

Disponibile Tubular / Tubeless

OPTIONAL:

- Lefty Option
- 15 mm
- 20 mm Axel

<PROFILE

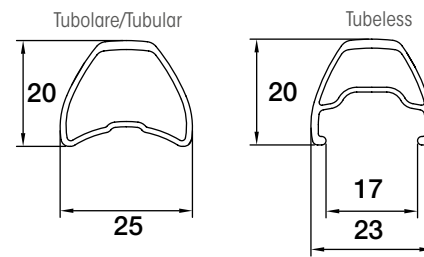

| | | | |
|-----------|--|----------|---------------------------|
| MODELLO | 27,5" mtb Tubolare/Tubeless/Copertoncino | | |
| ETRTO | Tubol. 596-25din/Tubel 584-17din | O.L.D. | 100/135 |
| VERSIONI | Shimano | FINITURA | Anodizzata nera con laser |
| CERCHIO | Alluminio 6082-T6 saldato, foro valvola 6.5 mm | | |
| RAGGI | Sapim laser 32 inox aero sfinati - ant./post. inc. x 2 | | |
| NIPPLES | Autobloccanti ABS L 13 in ergal | | |
| MOZZI | Versione GPMKCHMTBDisc, alluminio forgiato, cassetta Ergal su cuscinetti | | |
| BLOCCAGGI | Alluminio forgiato peso al paio 110 gr | | |
| PESO | Ant. 727 gr. - Post. 866 gr. Tot. 1593 gr. (+/- 5% senza bloccaggi e liquido GIPIEMME sealant) | | |

| | | | |
|----------|---|--------|---------------------------|
| MODEL | Clincher Tubular/Tubeless 27,5" mtb | | |
| ETRTO | Tubol. 593-25din/Tubel 884-17din | O.L.D. | 100/135 |
| VERSIONS | Shimano | FINISH | Black anodized with laser |
| RIM | Aluminium welded 6082-T6, valve hole 6.5 mm | | |
| SPOKES | Sapim laser 32 stainless steel aero-spoke, double size Front /Rear cross by 2 | | |
| NIPPLES | Self-blocking ABS L 13 Ergal | | |
| HUB | GPMKCHMTBDisc, forged aluminium with Ergal cassette on sealed bearings | | |
| Q.R. | Forged aluminium - weight 110 gr. | | |
| WEIGHT | Front 727gr. - Rear 866 gr. Tot. 1593 gr. (+/- 5% without quick release and GIPIEMME sealant) | | |



<UTILIZATION

Tubolare/Tubular

- Xc** ●●●●●●
- Marathon** ●●●●●●
- Trail** ●●
- CROSSmountain** ●
- Enduro** ●

Tubeless/Clincher

- Xc** ●●●●●●
- Marathon** ●●●●●●
- Trail** ●●●●
- CROSSmountain** ●●●●●●
- Enduro** ●



<UTILIZATION

- Xc** ●●●●
- Marathon** ●●●●●●
- Trail** ●●●●●●
- CROSSmountain** ●●●●●●●●
- Enduro** ●●



<T 584 27.5" mtb carbon ultralight

- OPTIONAL:**
- Lefty Option
 - 15 mm
 - 20 mm Axel

<PROFILE

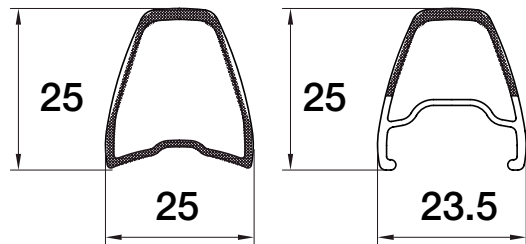

27.5" Tubeless Copertoncino

PESO: Ant. 683 gr. - Post. 813 gr. Tot. 1496 gr.
(+/- 7% senza bloccaggi)
ETRTO: 584-25 din O.L.D. 100/135



| | | | |
|-----------|---|----------|-------------------|
| MODELLO | Tubolare/Tubeless 27,5" - mtb | | |
| ETRTO | 596-25 din O.L.D. | O.L.D. | 100/135 |
| VERSIONI | Shimano | FINITURA | Fibra di carbonio |
| CERCHIO | Monoscocca 100% fibra di carbonio alto 25 mm - foro valvola 6.5 mm | | |
| RAGGI | Sapim laser Inox aero sfinati - 24 ant./ 24 post. inc. x 2 | | |
| NIPPLES | Autobloccanti ABS L 13 in Ergal con rondelle | | |
| MOZZI | Versione GPMCHMTBDisc, alluminio forgiato, cassetta Ergal su cuscinetti | | |
| BLOCCAGGI | Alluminio forgiato peso al paio 110 gr | | |
| PESO | Ant. 601 gr. - Post. 686 gr. Tot. 1287 gr. (+/- 7% senza bloccaggi) | | |

| | | | |
|----------|---|--------|--------------|
| MODEL | Tubular 27,5" mtb | | |
| ETRTO | 596-25 din O.L.D. | O.L.D. | 100/135 |
| VERSIONS | Shimano | FINISH | Carbon fiber |
| RIM | 100% carbon fiber monocoque height 25 mm, valve hole 6.5 mm | | |
| SPOKES | Sapim laser 24 F/24 R, stainless steel aero-spoke, double size Front /Rear cross by 2 | | |
| NIPPLES | Self-locking ABS L 13 Ergal with washers | | |
| HUB | GPMCHMTBDisc, forged aluminium with Ergal cassette on sealed bearings | | |
| Q.R. | Forged aluminium - weight 110 gr. | | |
| WEIGHT | Front 601 gr. - Rear 686 gr. Tot. 1287 gr. (+/- 7% without quick release) | | |

<Roccia 29" 27.5" 26"

- OPTIONAL:**
- Lefty Option
 - 15 mm
 - 20 mm Axel

<PROFILE

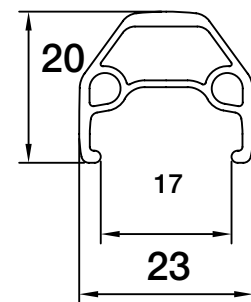

COLORI/COLOR

- Bianco/White
- Nero/Black

26" Copertoncino

PESO: Ant. 770 gr. - Post. 920 gr. Tot. 1690 gr.
(+/- 5% senza bloccaggi e liquido GIPIEMME sealant)
ETRTO: 559-17din 100/135
RAGGI: 24 inox sapim Leader - ant./post. inc. x 2

27.5" Copertoncino

PESO: Ant. 870 gr. - Post. 1020 gr. Tot. 1890 gr.
(+/- 5% senza bloccaggi e liquido GIPIEMME sealant)
ETRTO: 584-17din O.L.D. 100/135
RAGGI: 32 inox sapim Leader - ant./post. inc. x 2

29" Copertoncino

PESO: Ant. 945 gr. - Post. 1100 gr. Tot. 2045 gr.
(+/- 5% senza bloccaggi e liquido GIPIEMME sealant)
ETRTO: 622-17din O.L.D. 100/135
RAGGI: 32 inox sapim Leader - ant./post. inc. x 2

| | | | |
|-----------|--|----------|---|
| MODELLO | Copertoncino 26" 27.5" 29" mtb | | |
| VERSIONI | Shimano | FINITURA | Anodizzato nero con laser Bianche con etichette |
| CERCHIO | Alluminio 6005-T6, foro valvola 6.5 mm | | |
| NIPPLES | Autobloccanti ABS L 13 | | |
| MOZZI | Alluminio forgiato, cassetta Ergal su cuscinetti | | |
| BLOCCAGGI | Alluminio forgiato peso al paio 110 gr | | |

| | | | |
|----------|---|--------|---|
| MODEL | Clincher 26" mtb | | |
| VERSIONS | Shimano | FINISH | black anodized with laser white paint w/sticker |
| RIM | Aluminium welded 6082-T6, valve hole 6.5 mm | | |
| NIPPLES | Self-locking ABS L 13 | | |
| HUB | Forged aluminium with Ergal cassette on sealed bearings | | |
| Q.R. | Forged aluminium - weight 110 gr. | | |



<UTILIZATION

xc ●●●
marathon ●●●
trail ●●●●
CROSSmountain ●●●●●
enduro ●●●●●

Book
2013

<UTILIZATION

xc ●●●●
marathon ●●●●
trail ●●●●●
CROSSmountain ●●●●●●
enduro ●●●●●●●



<Roccia 27.5" 26"

equipe

COLORI/COLOR

□ Bianco/White ■ Nero/Black

<PROFILE

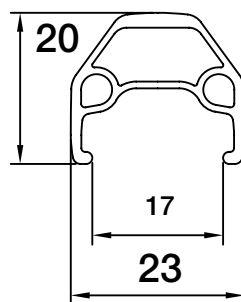
**26" Copertoncino**

PESO: vedi dati in tabella
 ETRTO: vedi dati in tabella

27.5" Copertoncino

PESO: Ant. 1053gr. - Post 1177 gr. Tot. 2230 gr.
 (+/-5% senza bloccaggi)
 ETRTO: 584-17din O.L.D. 100/135



| | | | |
|-----------|--|----------|---|
| MODELLO | Copertoncino 26" mtb | | |
| ETRTO | 559-17din | O.L.D. | 100/135 |
| VERSIONI | Shimano | FINITURA | Anodizzato nero con laser Bianche con etichette |
| CERCHIO | Alluminio 6005-T6, foro valvola 6.5 mm | | |
| RAGGI | Sapim 28 Inox - ant./post.inc X2 | | |
| NIPPLES | Autobloccanti ABS L 13 | | |
| MOZZI | Alluminio Forgiato, cassetta e perno in Acciaio - su cuscinetti | | |
| BLOCCAGGI | Alluminio forgiato peso al paio 110 gr | | |
| PESO | Ant. 908gr. - Post 1085gr. Tot. 1993 gr. (+/-5% senza bloccaggi) | | |

| | | | |
|----------|--|--------|---|
| MODEL | Clincher 26" mtb | | |
| ETRTO | 559-19.5din | O.L.D. | 100/135 |
| VERSIONS | Shimano | FINISH | black anodized with laser white paint w/sticker |
| RIM | Aluminium welded 6082-T6, valve hole 6.5 mm | | |
| SPOKES | Sapim nr 28 Stainless steel Front/Rear inc.X2 | | |
| NIPPLES | Self-locking ABS L 13 | | |
| HUB | Forged Alloy, steel cassette and axel | | |
| Q.R. | forged aluminium - Weight 110 gr. | | |
| WEIGHT | front 908gr. - rear 1085gr. Tot. 1993gr. (+/- 5% with out quick release) | | |

< T-REX

enduro

Axel 12mm Old 143 +120 gr

<PROFILE

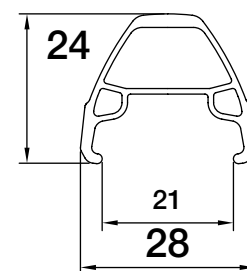

| | | | |
|-----------|--|----------|---------------------------|
| MODELLO | Copertoncino 26" mtb disc | | |
| ETRTO | 559-21din | O.L.D. | 100/135 |
| VERSIONI | Shimano | FINITURA | Anodizzato nero con laser |
| CERCHIO | Alluminio 6005-T6 saldato, foro valvola 8,5 | | |
| RAGGI | Sapim 24 raggi inox | | |
| NIPPLES | Autobloccanti ABS | | |
| MOZZI | Alluminio forgiato Asse Ant STD 9/15/20mm Post. Standard (opzional 12mm) | | |
| BLOCCAGGI | Non forniti | | |
| PESO | Ant. 927 gr. Post. 992gr. - Tot. 1919gr. (+/-5% senza bloccaggi) | | |

| | | | |
|----------|--|--------|---------------------------|
| MODEL | Clincher 26" mtb disc | | |
| ETRTO | 559-21din | O.L.D. | 100/135 |
| VERSIONS | Shimano | FINISH | Black anodized with laser |
| RIM | Aluminium weld 6005-T6, welded 6,5 mm | | |
| SPOKES | Sapim nr.24 stainless steel | | |
| NIPPLES | Self locking ABS L13 | | |
| HUB | Forged aluminium - Ergal cassette on seal bearings Axel STD/15/18mm, Post standard (optional 12mm) | | |
| Q.R. | with out | | |
| WEIGHT | Front 927 gr. - Rear 992 gr. Tot. 1919gr. (+/- 5% with out quick release) | | |



<T2-30S

COLORI/COLOR

□ Bianco/White ■ Nero/Black



<PROFILE

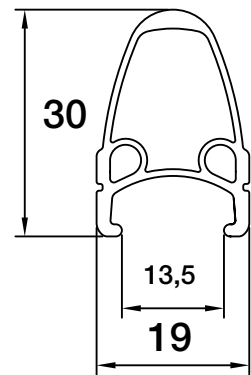

| | | | |
|-----------|--|--------|----------------------------|
| MODELLO | Copertoncino 28" 700 | | |
| ETRTO | 622-13.5 | O.L.D. | SH/CA 100/130 - FW 100/135 |
| VERSIONI | Shimano, Campagnolo, filetto | | |
| CERCHIO | Alluminio 6005-T6, foro valvola 6.5 mm | | |
| RAGGI | Ant./Post. n.32 inc.T2 | | |
| NIPPLES | Standard | | |
| MOZZI | Alluminio forgiato | | |
| BLOCCAGGI | Acciaio | | |
| FINITURA | Verniciata bianco/nero | | |

| | | | |
|----------|--------------------------------------|--------|----------------------------|
| MODEL | Clincher 28" 700 | | |
| ETRTO | 622-13.5 din | O.L.D. | SH/CA 100/130 - FW 100/135 |
| VERSIONS | Shimano, Campagnolo, Freewheel | | |
| RIM | Aluminium 6005-T6, valve hole 6.5 mm | | |
| SPOKES | 32 Front /Rear cross by T2 | | |
| NIPPLES | Standard | | |
| HUB | Forged aluminium | | |
| Q.R. | Steel | | |
| FINISH | White/black painted | | |

Book
2013

<T2-24S

juniores 20" 24" 26"

COLORI/COLOR

 Bianco/White Nero/Black

Opzione raggi Inox e mozzo cuscinetti



<PROFILE

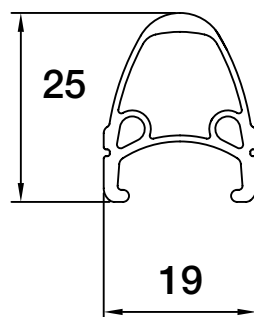

| | | | |
|-----------|---|--------|----------------------------|
| MODELLO | Copertoncino 20" - 24" - 26" 700 | | |
| VERSIONI | Shim., Campagnolo, Filetto | O.L.D. | SH/CA 100/130 - FW 100/135 |
| ETRTO | 20" 420- 13,5 din / 24" 520- 13,5 din / 26" 571- 13,5 din | | |
| CERCHIO | Alluminio 6005-T6, foro valvola 6.5 mm | | |
| RAGGI | Ant./Post. n.32 inc.T2 | | |
| NIPPLES | Standard | | |
| MOZZI | Alluminio forgiato | | |
| BLOCCAGGI | Acciaio | | |
| FINITURA | Verniciata silver/nera | | |

| | | | |
|----------|---|--------|----------------------------|
| MODEL | Clincher 20" - 24" - 26" 700 | | |
| VERSIONS | Shim., Camp., Freewheel | O.L.D. | SH/CA 100/130 - FW 100/135 |
| ETRTO | 20" 420- 13,5 din / 24" 520- 13,5 din / 26" 571- 13,5 din | | |
| RIM | Aluminium 6005-T6, valve hole 6.5 mm | | |
| SPOKES | 32 Front /Rear cross by T2 | | |
| NIPPLES | Standard | | |
| HUB | Forged aluminium | | |
| Q.R. | Steel | | |
| FINISH | Silver/black painted | | |

<Rock

COLORI/COLOR

 Bianco/White Nero/Black

<PROFILE

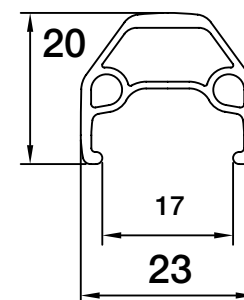

| | | | |
|-----------|--|----------|--------------------------|
| MODELLO | Copertoncino 28" 700 C | | |
| ETRTO | 622-13,5 din | O.L.D. | 100/120 |
| VERSIONI | Pista /Ruota Libera | FINITURA | Verniciato nero o bianco |
| CERCHIO | Alluminio 6005-T6, foro valvola 7 mm | | |
| RAGGI | 32 neri | | |
| NIPPLES | L 13 mm | | |
| MOZZI | Alluminio forgiato su sfere | | |
| BLOCCAGGI | N/P | | |
| PESO | Ant. 1159 gr. - Post. 1230 gr.Tot. 2389 gr. (+/- 5%) | | |

| | | | |
|----------|--|--------|----------------------|
| MODEL | Clincher 28" 700 C | | |
| ETRTO | 622-13,5 din | O.L.D. | 100/120 |
| VERSIONS | Track/FreeWheels | FINISH | Paint black or white |
| RIM | Aluminium 6005-T6, valve hole 7 mm | | |
| SPOKES | 32 black | | |
| NIPPLES | L 13 mm | | |
| HUB | Forged alloy on lose ball | | |
| Q.R. | N/P | | |
| WEIGHT | Front 1159 gr. - Rear 1230 gr.Tot. 2389 gr. (+/- 5%) | | |



Book 2013



<T2-24L 28" trekking filetto/cassetta/disco

COLORI/COLOR

□ Bianco/White ■ Nero/Black



<PROFILE

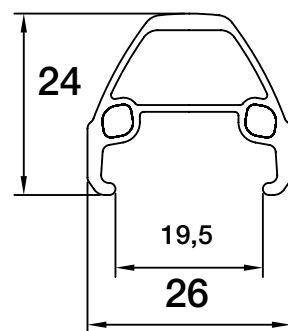

<T2-24L 26"/29" MTB filetto/cassetta/disco

COLORI/COLOR

□ Bianco/White ■ Nero/Black



<PROFILE

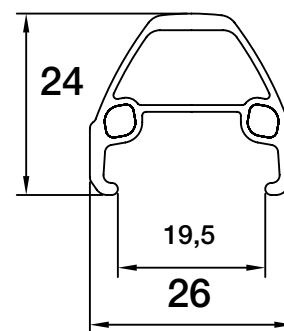

| | | | |
|-----------|--------------------------------|--------|---------|
| MODELLO | Copertoncino 28" | | |
| ETRTO | 622-19.5 din | O.L.D. | 100/135 |
| VERSIONI | Shimano, filetto, disco | | |
| CERCHIO | Alluminio, foro valvola 8.5 mm | | |
| RAGGI | Ant./Post. n.32 inc.T2 | | |
| NIPPLES | Standard | | |
| MOZZI | Alluminio forgiato | | |
| BLOCCAGGI | Acciaio | | |
| FINITURA | Verniciata bianco/nero | | |

| | | | |
|----------|------------------------------|--------|---------|
| MODEL | Clincher 28" | | |
| ETRTO | 622-19.5 din | O.L.D. | 100/135 |
| VERSIONS | Shimano, freewheels, disc | | |
| RIM | Aluminium, valve hole 8.5 mm | | |
| SPOKES | 32 Front/Rear cross by T2 | | |
| NIPPLES | Standard | | |
| HUB | Forged aluminium | | |
| Q.R. | Steel | | |
| FINISH | White/black painted | | |

| | | | |
|-----------|--|--------|---------|
| MODELLO | Copertoncino 26" MTB / 29" MTB | | |
| ETRTO | 559-19,5 din | O.L.D. | 100/135 |
| VERSIONI | Shimano disco | | |
| CERCHIO | Alluminio, foro valvola 8.5 mm | | |
| RAGGI | Ant./Post. n.32 inc. | | |
| NIPPLES | Standard | | |
| MOZZI | Alluminio forgiato | | |
| BLOCCAGGI | Acciaio | | |
| FINITURA | Verniciata bianco / Anodizzazione nera | | |

| | | | |
|----------|------------------------------|--------|---------|
| MODEL | Clincher 26" MTB / 24" MTB | | |
| ETRTO | 559-19,5 din | O.L.D. | 100/135 |
| VERSIONS | Shimano disc | | |
| RIM | Aluminium, valve hole 8.5 mm | | |
| SPOKES | 32Front/Rear cross by 2 | | |
| NIPPLES | Standard | | |
| HUB | Forged aluminium | | |
| Q.R. | Steel | | |
| FINISH | White paint /black anodize | | |



H 6.0 Tubolare
Tubolare / Tubular
Dimensioni / Size:
28" - Etrto 632 h 60 mm - L 20 mm
Materiale / Material:
100% Fibra Carbonio
100% Carbon Fiber
Fori a richiesta / Holes on request
Peso / Weight: 480 Gr.

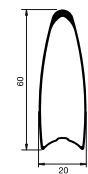

Cerchio H40 Tubolare Ciclocross
Tubolare / Tubular
Dimensioni / Size:
28" - Etrto 632 h 40,5 mm - L 21 mm
Materiale / Material:
100% Fibra Carbonio
100% Carbon Fiber
Fori a richiesta / Holes on request
Peso / Weight: 379 Gr.

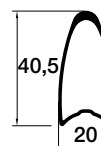

H 4.0 Tubolare
Tubolare / Tubular
Dimensioni / Size:
28" - Etrto 632 h 40,5 mm - L 19 mm
Materiale / Material:
100% Fibra Carbonio
100% Carbon Fiber
Fori a richiesta / Holes on request
Peso / Weight: 379 Gr.

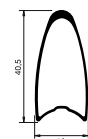

H 2.5 Tubolare
Tubolare / Tubular
Dimensioni / Size:
28" - Etrto 632 h 24,5 mm - L 19 mm
Materiale / Material:
100% Fibra di Carbonio
100% Carbon Fibre
Fori a richiesta / Holes on request
Peso / Weight: 320 gr

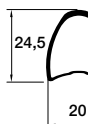

H 5.5 Copert. AluCarbon
Copertoncino / Clincher
Dimensioni / Size:
28" - Etrto 622 / 13,5 Din - h 55mm - L 19mm
Materiale / Material:
Alluminio 6082T6 e Fibra Di Carbonio
Alloy 6082T6 with Carbon Fiber
Fori / Holes: 20
Peso / Weight: 620 Gr.

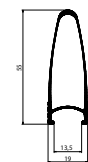

H5.5 Equip Copert. AluCarbon
Copertoncino / Clincher
Dimensioni / Size:
28" - Etrto 622 / 13,5 Din
Materiale / Material:
100% Fibra Carbonio
100% Carbon Fiber
Fori / Holes: 20 - 24
Peso / Weight: 700 Gr.

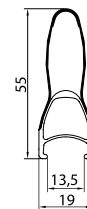

H40 Copertoncino AluCarbon
Copertoncino / Clincher
Dimensioni / Size:
28" - Etrto 632 / 13,5 Din - h 40mm - L 19mm
Materiale / Material:
Alluminio 6082T6 e Fibra Di Carbonio
Alloy 6082T6 with Carbon Fiber
Fori / Holes: 20
Peso / Weight: 540 Gr.

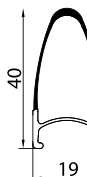

H 2.5 Copertoncino AluCarbon
Copertoncino / Clincher
Dimensioni / Size:
28" - Etrto 622 / 13,5 Din - h 24,5mm - L 19mm
Materiale / Material:
Alluminio 6082T6 Fibra Di Carbonio
Alloy 6082T6 with Carbon Fiber
Fori / Holes: 20
Peso / Weight: 498 Gr.

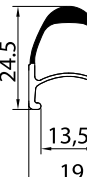

Cerchi carbonio alluminio speciali MTB



Sierra MTB Tubolare
Tubolare / Tubular
Dimensioni / Size:
26" Mtb - Etrto 571 / Din - h 40mm - L 25mm
Materiale / Material:
100% Fibra Carbonio
100% Carbon Fiber
Fori / Holes: 24 - 28
Peso / Weight: 380 Gr.

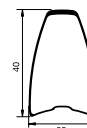

T584 MTB Tubolar
Tubolare / Tubular
Dimensioni / Size:
27,5-650B" Mtb - Etrto 596 - 25Din - h 25mm
Materiale / Material:
100% Fibra Carbonio
100% Carbon Fiber
Fori / Holes: As request
Peso / Weight: 350 Gr.

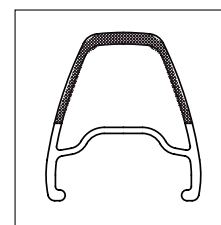
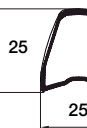

T584 MTB Tubeless Copertoncino
Copertoncino / Clincher - Tubeless
Dimensioni / Size:
27,5-650B" Mtb - Etrto 584
17Din - h 25mm - L 25mm
Materiale / Material:
Alluminio 6082T6 Fibra Di Carbonio
Alloy 6082T6 with Carbon Fiber
Fori / Holes: As request
Peso / Weight: 425 Gr.

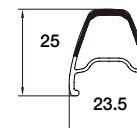

Kenya Tubolar
Tubolare / Tubular
Dimensioni / Size:
26" Mtb - Etrto 571 - h 20 mm - L 25 mm
Materiale / Material:
Alluminio 6082T6 / Alloy 6082T6
Fori / Holes: 24 - 28
Peso / Weight: 380 Gr.

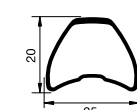

Kenya / Kenya tubeless/Copertonc.
Copertoncino
Clincher/Tubeless
Dimensioni / Size:
26" - Etrto 559 / 18 Din - h 20 mm - L 23 mm
Materiale / Material:
Alluminio 6082T6 / Alloy 6082T6
Fori / Holes: 24 - 28
Peso / Weight: 380 Gr.

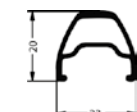

Enduro T-REX
Dimensione / Size:
26" Etrto 559 - 18Din
Materiale / Material:
Alluminio 6005T6 saldato
Fori / Holes: 32
Peso / Weight:
26": 530gr.

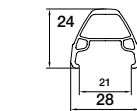

Cerchi alluminio leghe speciali corsa



Krono
Tubolare / Tubular
Dimensioni / Size:
28" - Etrto 632 / 13,5 Din
Materiale / Material:
Lega Di Alluminio / Aluminium Alloy
Fori / Holes: 20 - 24 (8x3)
Peso / Weight: 420 Gr.

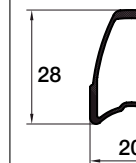

1.55
Copertoncino / Clincher
Dimensioni / Size:
28" - Etrto 622 / 13,5 Din - h 30mm - L 18mm
Materiale / Material:
Alluminio 6082T6/ Alloy 6082T6
Fori / Holes: 20 - 24 (8x3)
Peso / Weight: 465 Gr.

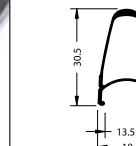

716 2010 Saldato
Copertoncino / Clincher
Dimensioni / Size: 28" - Etrto 622 / 13,5 Din / 26" - Etrto 571
Materiale / Material:
Lega Di Alluminio / Aluminium Alloy
Fori / Holes: 16 (8x2) 16 Std
Peso / Weight: 663 Gr.

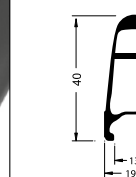

Cerchi alluminio 6005 corsa



A40
Copertoncino / Clincher
Dimensioni / Size:
28" - Etrto 622 / 13,5 Din
h 40mm - L 19mm
Materiale / Material:
Alluminio 6005T6 / Alloy 6005T6
Fori / Holes: 28 - 32 - 36
Peso / Weight: 745 Gr.

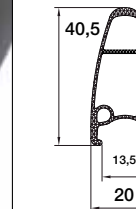



Cerchi alluminio 6005 MTB-Trekking

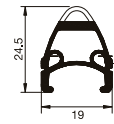

Phantom
Copertoncino / Clincher
Dimensioni / Size:
28" - Etrto 622 / 13,5 Din
h 24,5/21mm - L 19mm
Materiale / Material:
Alluminio 6005T6 / Alloy 6005T6
Fori / Holes: 24 / 28 (7x4) / 36 (9x4)
Peso / Weight: 600 Gr.

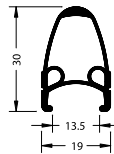

030S
Copertoncino / Clincher
Dimensioni / Size:
28" - Etrto 622 / 13,5 Din
h 30mm - L 19mm
Materiale / Material:
Alluminio 6005T6 / Alloy 6005T6
Fori / Holes: 20 / 24 (12x2) / 28 (14x2) / 32/36
Peso / Weight: 655 Gr.

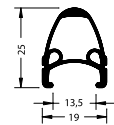

024S
Copertoncino / Clincher
Dimensioni / Size: h 25mm - L 19mm
28" - Etrto 622 / 13,5 Din / 26" - Etrto 559 / 16,5 Din
24" - Etrto 540 / 18 Din / 20" - Etrto 520 / 18 Din
Materiale / Material:
Alluminio 6005T6 / Alloy 6005T6
Fori / Holes: 24 / 32 / 36
Peso / Weight: 540 Gr.

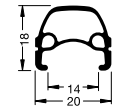

032S
Copertoncino / Clincher
Dimensioni / Size:
28" - Etrto 622 / 14 Din
h 18mm - L 20mm
Materiale / Material:
Alluminio 6005T6 / Alloy 6005T6
Fori / Holes: 32 - 36
Senza Boccole / Without Eyelets
Peso / Weight: 450 Gr.

Cerchi bici elettriche

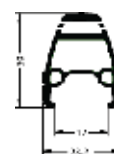

TT30 Elettric
Copertoncino / Clincher
Dimensioni / Size:
28" - Etrto 622 / 13,5 Din
h 30mm - L 23,2mm
Materiale / Material:
Alluminio 6005T6 / Alloy 6005T6
Fori / Holes: 32 / 32(8x4) / 36 / 36(9x4)
Peso / Weight: 590 Gr.

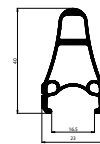

Raktor
Copertoncino / Clincher
Dimensioni / Size: h 40mm - L 23mm
26" - Etrto 559 / 16,5 Din
28" - Etrto 622 / 16,5 Din
Materiale / Material:
Alluminio 6005T6 / Alloy 6005T6
Fori / Holes: 26": 32 - 36 / 28": 32
Peso / Weight: 26": - Gr. / 28": 840 Gr.

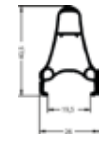

Cr
Copertoncino / Clincher
Dimensioni / Size:
26" - Etrto 559 / 19 Din
28" - Etrto 622 / 16,5 Din
h 40,5 mm - L 26 mm
Materiale / Material:
Alluminio 6005T6 / Alloy 6005T6
Fori / Holes: 36
Peso / Weight: 26" - Gr. / 28" 890 Gr.



TT4-30L
Copertoncino / Clincher
Dimensioni / Size:
28" - Etrto 622 / 17 Din
h 30 mm - L 23,2 mm
Materiale / Material:
Alluminio 6060T6 / Alloy 6060T6
Fori / Holes: 28 (7x4) / 36 (9x4)
Peso / Weight: 730 Gr.

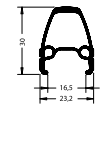

030L Thunder
Copertoncino / Clincher
Dimensioni / Size:
28" - Etrto 622 / 17 Din
26" - Etrto 571 / 17 Din
h 30 mm - L 23,2 mm
Materiale / Material:
Alluminio 6005T6 / Alloy 6005T6
Fori / Holes: 26": 32 - 36 / 28": 32 - 36
Peso / Weight: 26": 580 Gr. / 28": 600 Gr.

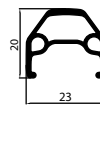

Roccia
Copertoncino / Clincher
Dimensioni / Size: h 20 mm - L 23 mm
20" - Etrto 405 / 18 Din / 24" - Etrto 507 / 18 Din
26" - Etrto 559 / 18 Din / 28" - Etrto 622 / 18 Din
Materiale / Material:
Alluminio 6005T6 / Alloy 6060T6
Fori / Holes: 20 - 24 (8x3)
Peso / Weight: 490 Gr.

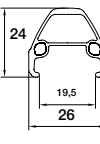

Nepal
Dimensione / Size:
26" Etrto 559 - 18Din / 28" Etrto 622 18Din
Materiale / Material:
Alluminio 6060T6
Fori / Holes: 32 - 36
Peso / Weight:
26": 540gr. / 28": 640gr.

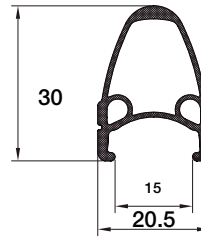

O30C
Copertoncino / Clincher
Dimensioni / Size:
28" - Etrto 622 / 15Din
h 30mm - L 19mm
Materiale / Material:
Alluminio 6005T6 / Alloy 6005T6
Fori / Holes: 32/36
Peso / Weight: 655 Gr.

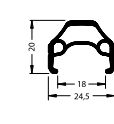

Alpyne
Dimensioni / Size: h 20 mm - L 24,5 mm
20" - Etrto 405 / 18 Din / 24" - Etrto 507 / 18 Din
26" - Etrto 559 / 18 Din / 28" - Etrto 622 / 18 Din
Materiale / Material:
Alluminio 6005T6 / Alloy 6060T6
Fori / Holes: 26": 36 / 28": 36
Peso / Weight: 26": 500 Gr. / 28" : 550 Gr.

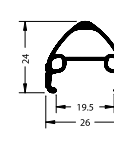

Mount
Dimensioni / Size:
20" - Etrto 406 / 19,5 Din
24" - Etrto 507 / 19,5 Din
26" - Etrto 559 / 19,5 Din
28" - Etrto 622 / 19,5 Din
h 24mm - L 26mm
Materiale / Material: Lega Di Alluminio 6060T6 / Alloy 6060T6
Fori / Holes: 32 - 36
Peso / Weight:
20": 450 Gr. / 24": 500 Gr.
26": 520 Gr. / 28": 620 Gr.

Cerchi Eco

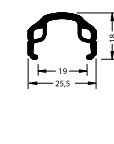

Ercoles
Dimensioni / Size:
24" - Etrto 507 / 19 Din
26" - Etrto 559 / 19 Din
26" 1 3/8 - Etrto 590 / 19 Din
28" - Etrto 622 / 19 Din
h 18 mm - L 25,5 mm
Materiale / Material:
Alluminio 6060T6 / Alloy 6060T6
Fori / Holes: 24" - 26" - 26" 1 3/8 - 28": 36
Peso / Weight:
20": 385 Gr. / 24": 460 Gr.
26": 500 Gr. / 26" 1 3/8 : 510 / 28": 550 Gr.

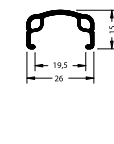

Mirage
Dimensioni / Size:
20" - Etrto 406 / 19,5 Din
24" - Etrto 507 / 19,5 Din
26" - Etrto 559 / 19,5 Din
26" 1 3/8 - Etrto 590 / 19,5 Din
28" - Etrto 622 / 19,5 Din
h 15mm - L 26mm
Materiale / Material: Alluminio 6060T6 / Alloy 6060T6
Fori / Holes: 20" : 28 - 36
24" - 26" - 26 13/8 : 36
Peso / Weight:
20": 280 Gr. / 24": 290 Gr.
26": 410 Gr. / 26" 1 3/8 : 430
28": 525 Gr.



Zenit
Dimensioni / Size:
26" - Etrto 559 / 16,5 Din
28" - Etrto 622 / 16,5 Din
h 16 mm - L 23 mm
Materiale / Material:
Alluminio 6060T6 / Alloy 6060T6
Fori / Holes: 36
Peso / Weight: 26" 515 Gr. / 28" 545 Gr.

Accessori



GPM Kit
tubeless



Chiavi a tubo per nipples
Nipples tools



Pattini freni per carbonio
Carbon fibre brake pad



Prolunghe valvole
Extend long valve



Grasso speciale Gipiemme, antiacqua
Waterproof Special grease



Borsa per ruote
Wheels bag



Espositore ruote
Display for wheels





GIPIEMME

www.gipiemme.com

GIPIEMME SRL

Via Salute, 34/1, 36028 Rossano Veneto (VI), Italy

Stabilimento/Work Address

Via Balbi, 13 - 31037 Loria (TV), Italy

Tel. +39 0423.755.939 - Fax +39 0423.755.022

gipiemme@gipiemme.com

www.gipiemme.com www.cerchinisi.it www.cerchinisi.com